

ROOFTOP UNIT DOWN DISCHARGE DOWN RETURN

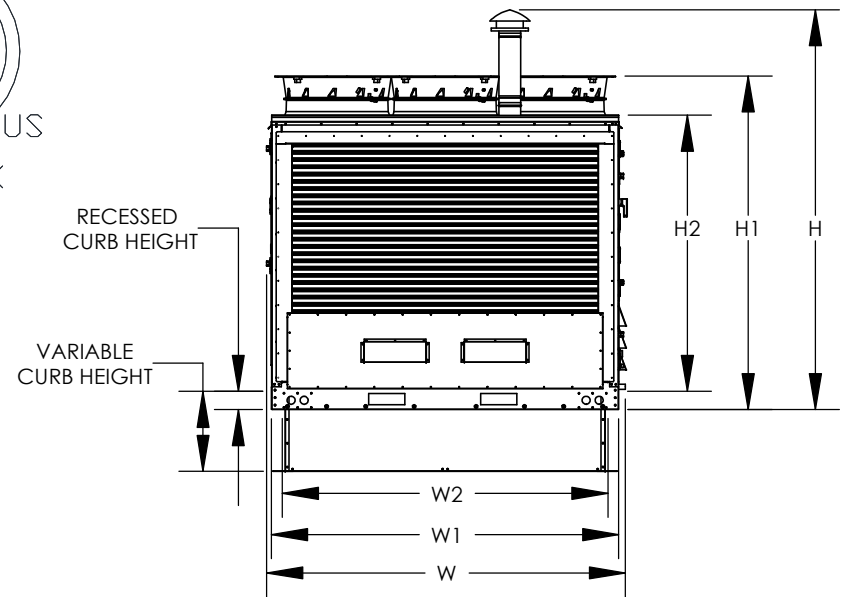
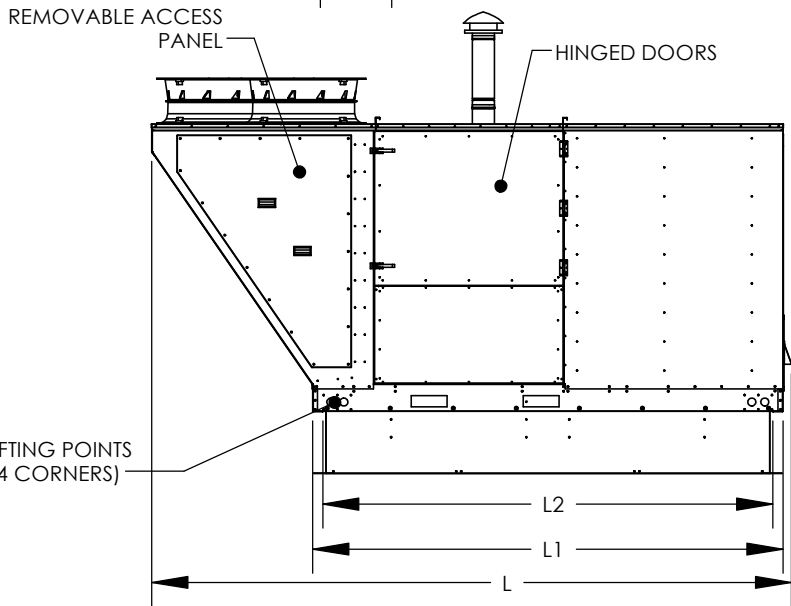
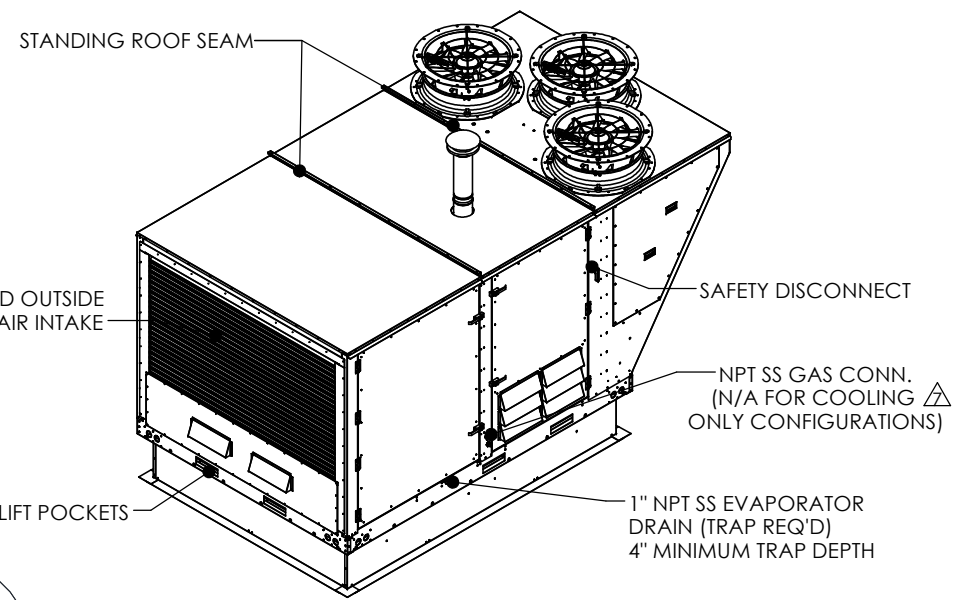
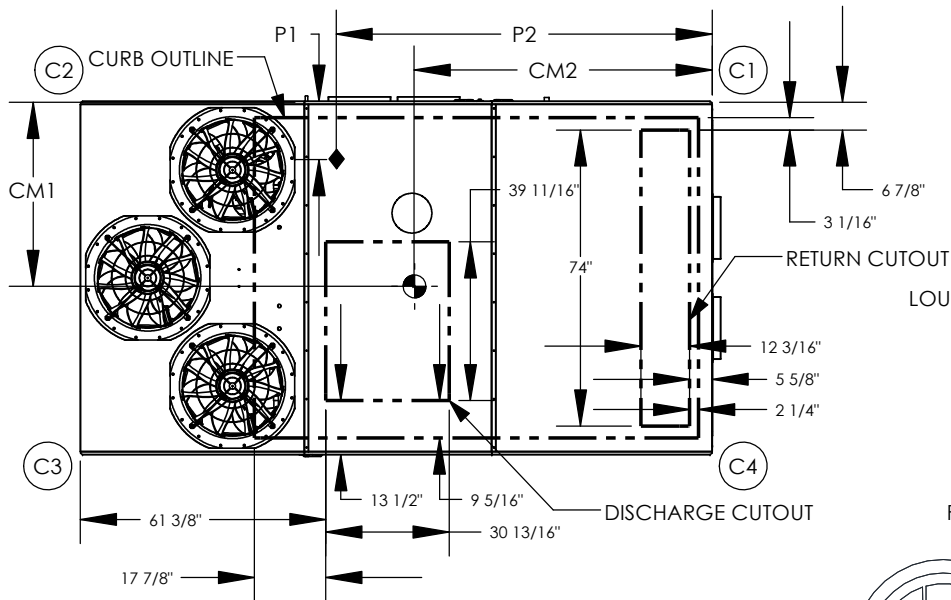

NOTES:

1. ROOF OPENING MUST BE 2" SMALLER THAN CURB DIMENSIONS IN BOTH DIRECTIONS
2. DO NOT OBSTRUCT OUTSIDE AIR INLET, OUTSIDE AIR COIL OR OUTSIDE AIR FAN
3. FLOOR MOUNT ISOLATORS LOCATED 1" FROM EITHER DIRECTION OF BASE, 39 5/8" FROM END OF BASE AND 43 3/8" FROM SIDE OF BASE. ACCOUNT FOR AN ADDITIONAL 5" FOR ISOLATOR HEIGHT QUANTITIES SUBJECT TO CHANGE DEPENDING ON FILTER TYPES
4. N/A FOR COOLING ONLY CONFIGURATIONS
5. SUBTRACT 310 LBS. FOR COOLING ONLY CONFIGURATIONS
6. 3/4" NPT SS GAS CONN. FOR 200-400 MBH FURNACES. 1" NPT SS GAS CONN. FOR 500 AND 600 MBH FURNACES
- 7.

RTU INFORMATION*

UNIT SIZE	AVAILABLE NOMINAL TONNAGE	INTAKE FILTERS	SUPPLY FILTERS	FURNACE CAPACITY (MBH)	ELECTRIC CAPACITY (KW)	APPROXIMATE WEIGHT (LBS)	CENTER OF MASS				CORNER WEIGHTS (LBS)				ENTERING POWER	
							CM1	CM2	C1	C2	C3	C4	P1	P2		
4	22, 25, 30	20 X 20 X 2 (8)	20 X 20 (24)	200 - 600	60-150	4500	44	74 1/2	812	1406	1447	835	14	94		

RTU DIMENSIONS*

UNIT SIZE	UNIT LENGTH (L)	OUTSIDE BASE LENGTH (L1)	INSIDE BASE LENGTH (L2)	UNIT HEIGHT (H)	UNIT HEIGHT TO FANS (H1)	MOUNTED HEIGHT (H2)	UNIT WIDTH (W)	BASE WIDTH (W1)	INSIDE BASE WIDTH (W2)	RECESSED CURB HEIGHT	CURB SIZE
4	160	117 1/2	112 1/2	96 1/2	83 3/8	69	89 3/4	86 3/4	81 1/4	4	80 x 111

*ALL DIMENSIONS IN INCHES UNLESS OTHERWISE SPECIFIED